



- AC 180~260VAC input only
- PFC 0.98@ 230VAC
- Protections: Short circuit, overload, over voltage, over temperature
- Built in remote sense function
- Built-in remote ON-OFF control
- Power good signal
- With parallel function(N+1)
- Can adjust from 25~100% output voltage by external control 1-5V
- Forced air cooling by built-in DC fan
- 2 years warranty



SPECIFICATION

ORDER NO.	SCP-800-09	SCP-800-12	SCP-800-15	SCP-800-24	SCP-800-48	
OUTPUT	SAFETY MODEL NO.	800S-P009	800S-P012	800S-P015	800S-P024	800S-P048
	DC VOLTAGE	9V	12V	15V	24V	48V
	RATED CURRENT	88A	66A	53A	33A	16A
	CURRENT RANGE	0 ~ 88A	0 ~ 66A	0 ~ 53A	0 ~ 33A	0 ~ 16A
	RATED POWER	792W	792W	795W	792W	768W
	RIPPLE & NOISE (max.) Note.2	90mVp-p	120mVp-p	150mVp-p	240mVp-p	480mVp-p
	VOLTAGE ADJ. RANGE	±5.0% Typical adjustment by potentiometer 25% ~ 100% adjustment by 1 ~ 5VDC external control				
	VOLTAGE TOLERANCE Note.3	±1.5%	±1.0%	±1.0%	±1.0%	±1.0%
	LINE REGULATION	±0.5%	±0.5%	±0.5%	±0.5%	±0.5%
	LOAD REGULATION	±1.0%	±0.5%	±0.5%	±0.5%	±0.5%
SETUP, RISE, HOLD TIME	500ms, 50ms, 12ms at full load					
INPUT	VOLTAGE RANGE	180 ~ 260VAC				
	FREQUENCY RANGE	47~63Hz				
	EFFICIENCY (Typ.)	83%	84%	85%	88%	89%
	AC CURRENT	4.5A/230VAC				
	INRUSH CURRENT (max.)	COLD START<60A/230VAC				
LEAKAGE CURRENT	<3.5mA / 240VAC					
PROTECTION	OVER LOAD	Current limiting 3 times(1.5s,3.0s,5.0s)Then intelligent auto recovery before shutdown				
	OVER VOLTAGE	110 ~ 135% Follow to output set up point Shut down o/p voltage, re-power on to recover				
	OVER TEMPERATURE	100°C / measure by heat sink, near transformer				
ENVIRONMENT	WORKING TEMP., HUMIDITY	-10 ~ +50°C @100% LOAD, +65°C @ 50% LOAD, 20 ~ 90% RH non-condensing				
	STORAGE TEMP., HUMIDITY	-20 ~ +85°C, 10~95% RH				
	TEMP. COEFFICIENT	±0.04%/°C (0 ~ 50°C)				
	VIBRATION	10 ~ 200Hz, 2G 10min./1cycle, 60min. each along X, Y, Z axes				
SAFETY & EMC	SAFETY STANDARDS	UL60950, TUV EN60950 Approved				
	EMI CONDUCTION & RADIATION	Compliance to EN55022 (CISPR22) Class A				
	HARMONIC CURRENT	Compliance to EN61000-3-2,-3, Class D				
	EMS IMMUNITY	Compliance to EN61000-4-2,3,4,5,6,8,11, Light industry level, criteria A				
	WITHSTAND VOLTAGE	I/P-O/P:3KVAC I/P-FG:1.5KVAC for 1min.				
ISOLATION RESISTANCE	I/P-O/P, I/P-FG:100M Ohms/500VDC					
OTHERS	POWER GOOD SIGNAL	Open collector of NPN transistor				
	SPECIAL FUNCTION	DC Voltage Adj., Remote sensing, remote control, parallel operation(refer to terminal instruction manual)				
	DIMENSION	290*120*68mm (L*W*H)				
	PACKING	2.3Kgs/pcs, 8pcs/20Kgs/CTN				
NOTE	<p>1. All parameters NOT specially mentioned are measured at 230VAC input, rated load and 25°C of ambient temperature.</p> <p>2. Ripple & noise are measured at 20MHz of bandwidth by using a 12" twisted pair-wire terminated with a 0.1uf & 47uf parallel capacitor.</p> <p>3. Tolerance : includes set up tolerance, line regulation and load regulation.</p>					

Mechanical Specification

Unit:mm

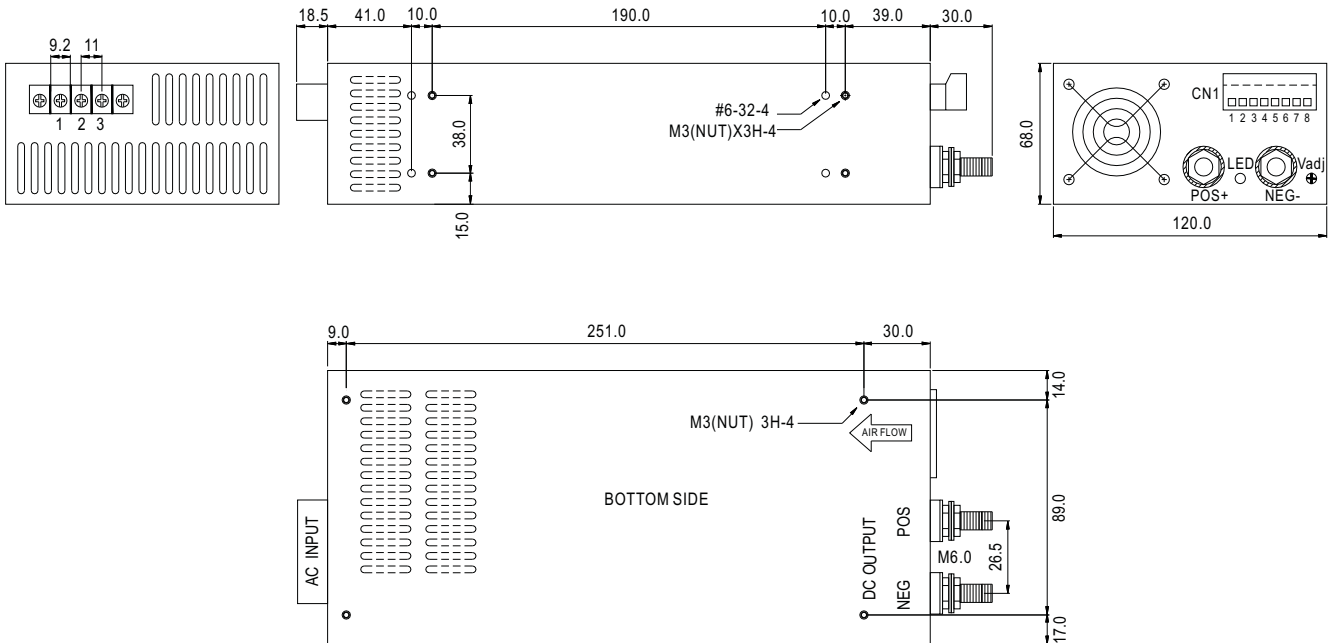

Terminal Pin. No. Assignment

Pin No.	Assignment
1	AC/L
2	AC/N
3	FG \perp

Control terminal Pin. No. Assignment (CN1) : Dinkle 51HDBC-O8P or equivalent

Pin No.	Assignment	Pin No.	Assignment	Mating With
1	VS+	5	PG	Dinkle 51SDB-O8P or equivalent
2	VS-	6	PAR	
3	VCI	7	GND	
4	VCO	8	INH	

Derating Curve

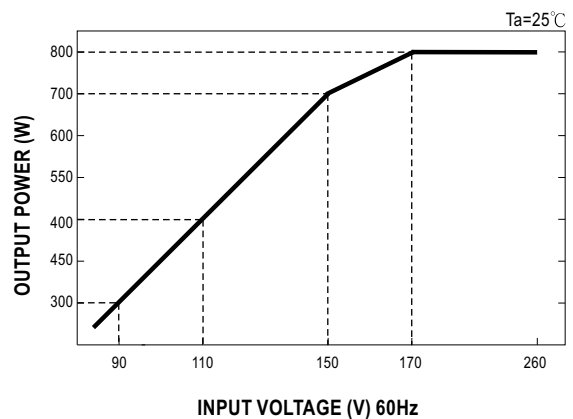
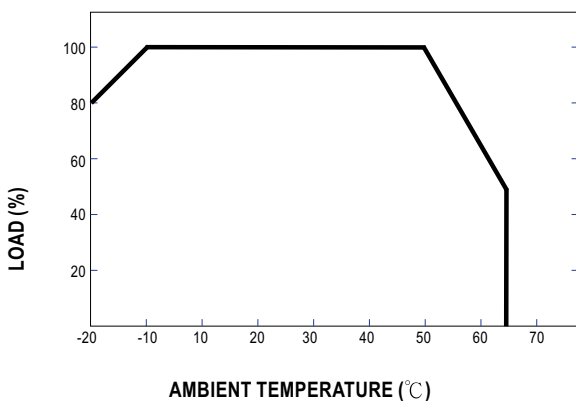

Control terminal instruction manual

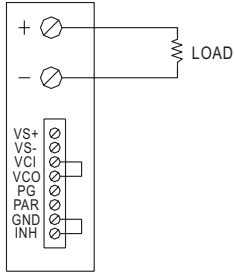

USING INTERNAL VOLTAGE CONTROL

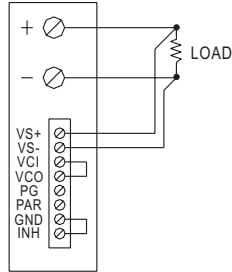

REMOTE SENSING

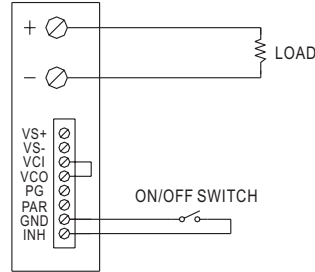

ON/OFF CONTROL BY SWITCH

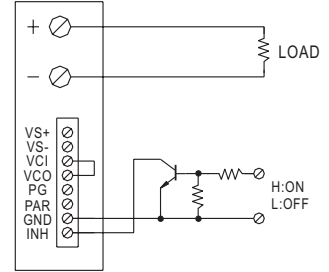

ON/OFF CONTROL BY TRANSISTOR

GOOD : LED OFF
FAIL : LED ON

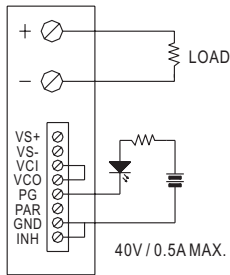

POWER GOOD SIGNAL

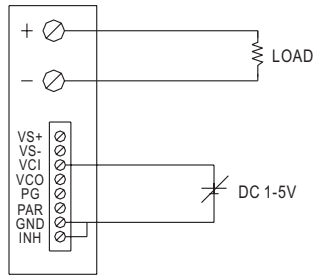

OUTPUT VOLTAGE ADJUST WITH DC 1-5V

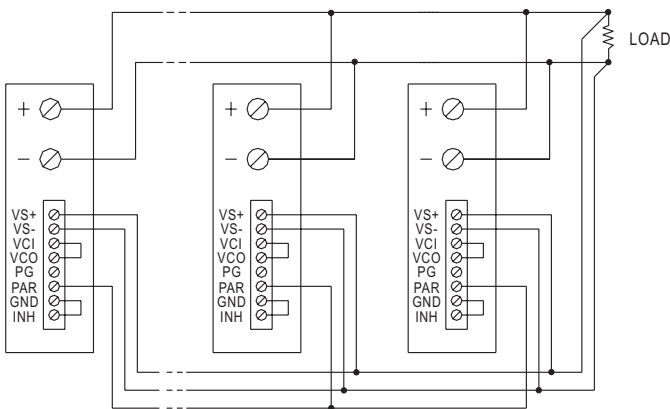
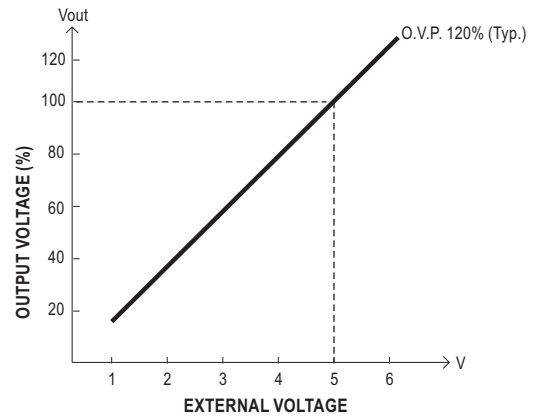

PARALLEL OPERATION WITH REMOTE SENSING

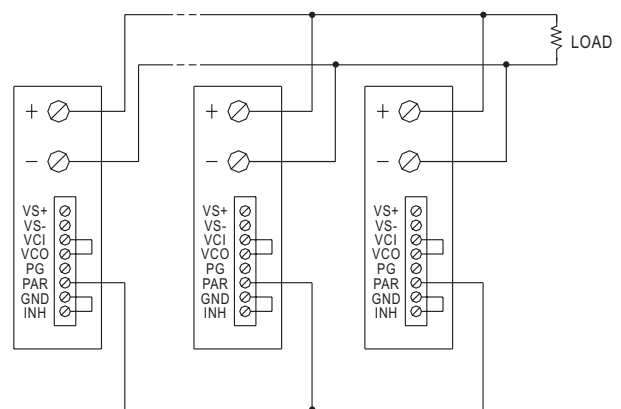

PARALLEL OPERATION WITHOUT REMOTE SENSING